

Design of a Continuous Production Energy Machine From Marine Trochoidal Waves

C. Inglés-Inglés*, S. A. Gómez-Lopera**

Dep. of Applied Physics, Universidad Politécnica de Cartagena (UPCT),
Campus Alfonso XIII, 30203 Cartagena, Spain

*E-mail address: cii0@alu.upct.es

**Corresponding author. Tel.: +34 968325599. E-mail address: salvador.glopera@upct.es

Abstract - This paper describes the development of a continuous production energy machine from marine trochoidal waves. Studying the characteristics of trochoidal waves in a geographical area near Cartagena, we have developed a device which taking advantage of the marine surface oscillation in order to produce the movement of a mechanical system, is able to transforming the mechanical energy into electrical energy.

Keywords – wave energy, point absorber, renewable energy, trochoidal waves

I. INTRODUCTION

At present, the marine renewable energetic resources are one of the sets of power sources with an enormous potential. However, its exploitation is minimally developed. Its origin is constituted by the character of immense energy collector that form the seas and oceans, which occupy about 70% of the surface of the planet and storing on 1.3×10^9 km³ of water, are the largest existing energy reserves on earth and besides renewable [1].

The wave resource is ten times more energetic than solar or wind. In addition, its high energy density, high availability and low environmental impact are a good starting point to study a type of energy in continuous development [2].

In Spain they are also pursuing a number of projects in wave energy, a total of 26 were recorded in 2013, mainly on the coast of País Vasco, Cantabria, Galicia and the Canary Islands.

Despite the lack of financial support to all renewable in Spain, big Spanish companies such as IBERDROLA, SENER or ABENGOA and research centers such as TECNALIA continue active in the ocean energy sector. There are also some enthusiastic small companies developing and testing wave and tidal current concepts. At a regional level, there is some support mainly from the two regional governments of the País Vasco and Canary Islands. Their respective open sea test facilities, bimep and PLOCAN, are now fully prepared to install and test wave energy devices. Mutriku OWC plant in the País Vasco has now more than three years of continuous

operation. There is further some initial interest in this field growing in other regions such as Andalucía and Galicia [3].

The operating principle of the device is being moved with a sinusoidal wave. The float and reciprocates by a mechanical system, connecting rod-crank, moving a generator rotor. This assembly is in a tight frame, supported on a structure at a given level of seabed [Fig. 1].

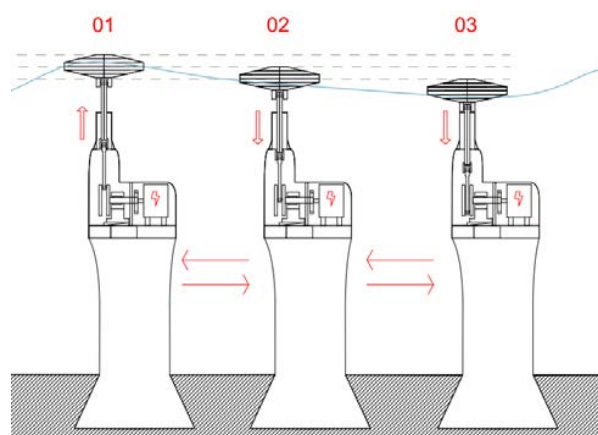

Fig.1. Point absorber in working

II. PROJECT DEVELOPMENT

Currently, existing technologies are very diverse, depending on the characteristics of the wave resource (wave height and period) and depending on the location of the device and the power selected for each unit. Therefore, the comparative advantage over existing systems is the use of a simple, robust, reliable and easy to maintain mechanism, leading to a reduction in costs. Moreover, its mechanical characteristics, the device performs as a continuous artifact energy production due to the pendulum movement that provides the wave for small wave heights.

The type of device for the conversion of wave energy of this project is known as point absorber, *i.e.*, two bodies that move vertically relative to each other by the effect of buoyant forces on bodies due to the wave elevations. The first body is called floater and is moved by the waves, while the second body, provides hydrodynamic stability,

maintains its position against displacement of the waves. For the design of the energy absorber it is needed a hydrodynamic study at the location where it is desired to install, in order to find the most frequent wave height, besides analyzing the characteristics of the trochoidal wave [4].

This project, which is being developed as Final Degree Work, has focused on the coastal area of Cartagena (see Fig.1). In the same issue of the energy needs of small facilities, but also can be used to power autonomous systems and to reinforce conventional generation facilities studied.

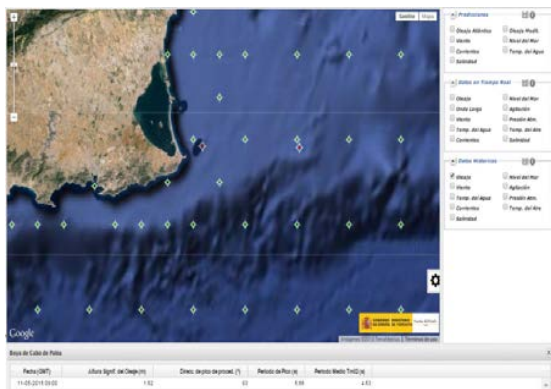

Fig.2. Coastal area of Cartagena.. Analysis of wave characteristics, predictive, real-time and historical data [5]

The study of waves in the geographic area of Cartagena, in particular, Node WANA2074090 (Length: 0.833 E, Latitude: 37.500 N) [see Fig.3] near the beach Gorguel. The study of the implantation of the device in this area is because there is a fish farm and a core of houses without access to the electricity grid.

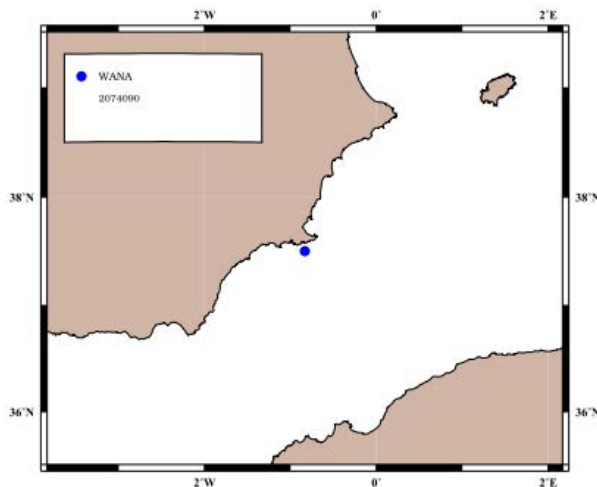

Fig.3. Coastal area of Cartagena, showing the selected node WANA2074090 [5]

Focusing on the WANA2074090 Node, in order to study wave of the year 2014-2015, distributions of peak period (T_p) and height (H_s) has been presented in [Figs. 4 and 5].

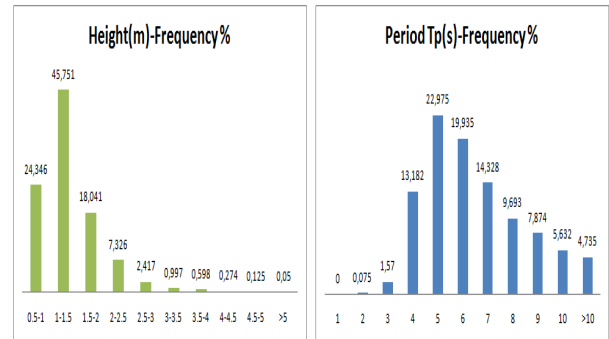

Fig.4. Distributions of Height and wave Period

Hs(m)	Tp (s)										Total
	1	2	3	4	5	6	7	8	9	10	
< 0.5	0.075	1.072	7.78	9.519	3.065	1.171	0.648	0.598	2.49	0.174	24.346
1		0.498	5.28	12.09	12.14	5.482	3.962	3.688	1.47	1.46	45.751
1.5			0.13	1.246	3.887	4.909	2.068	2.143	2.293	1.371	18.041
2				0.125	0.797	2.043	1.694	0.523	1.022	1.21	7.326
2.5					0.05	0.623	0.872	0.399	0.1	0.374	2.417
3						0.075	0.324	0.199	0.199	0.199	0.997
3.5							0.025	0.05	0.174	0.199	0.598
4								0.05	0.75	0.1	0.274
4.5									0.05		0.125
5									0.025		0.05
>5										0.075	0.075
Total	0.075	1.57	13.2	22.98	19.94	14.33	9.693	7.874	5.632	4.735	100

Fig.5. Statistics scalar wave series to the period 2014-2015

It is clear that the most often wave height generated is $H_s = 1$ m, with a wave period, $T_p = 5$ s.

III. CHARACTERISTICS OF TROCHOIDAL WAVE

Trochoidal waves are two-dimensional waves. In order to easily analyze changes in the characteristics of a wave as it propagates from the deep sea to the shore, it is necessary to consider [4]:

- The water is homogeneous and incompressible, and surface tension forces are negligible.
- Flow is irrotational. Thus there is no shear stress at the air-sea interface or at the bottom. The velocity potential must satisfy the Laplace equation for two-dimensional flow:

$$\frac{\partial^2 \phi}{\partial x^2} + \frac{\partial^2 \phi}{\partial z^2} = 0 \quad (2)$$

where x and z are the horizontal and vertical coordinates, respectively.

- The bottom is stationary, impermeable, and horizontal.
- The pressure along the air-sea interface is constant.

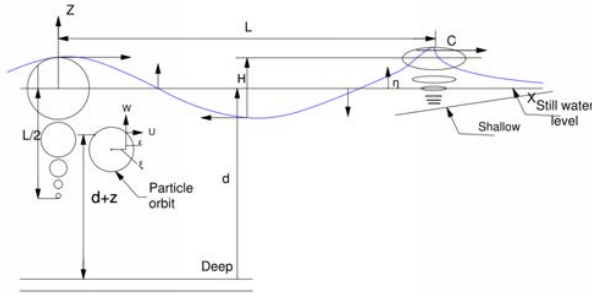

Fig.6. Definition of progressive surface wave parameters

Figure 6 depicts a monochromatic wave traveling at a phase celerity C on water of depth d in an x, z coordinate system. The X axis is the still water position and the bottom is at $z = d$. The wave surface profile is defined by $z = \eta$, where η is a function of x and time t . The wave length L and height H are as shown in the figure. Since the wave travels a distance L in one period T ,

$$C = \frac{L}{T} \quad (1)$$

The horizontal and vertical components of velocity of the water particles at any instant are u and w respectively. The horizontal and vertical coordinates of a particle of water at any point are given by ξ and ε , respectively. The coordinates refer to the center of the orbital path that the particle follows. At any instant, the particle of water is at a distance $d - (-z) = d + z$ above the bottom.

In transitional to shallow water, the orbits reach the bottom and become elliptical with the ellipses becoming flatter near the bottom. At the bottom the particles follow a reversing horizontal path.

The following dimensionless parameters are often used:

Wave number:

$$k = 2\frac{\pi}{L} \quad (3)$$

Wave angular frequency:

$$\sigma = 2\frac{\pi}{T} \quad (4)$$

Using the Laplace equation, the velocity potential can be written as

$$\phi = \frac{gH}{2\sigma} \frac{\cosh(d+z)}{\cosh kd} \sin(kx - \sigma t) \quad (5)$$

Wave celerity and length for any given water depth and wave are

$$C_0 = \frac{gT}{2\pi} \quad (6)$$

and

$$L_0 = \frac{gT^2}{2\pi} \quad (7)$$

The water particle velocity and acceleration as well as the pressure field in a wave are all needed to determine wave-induced forces on various types of coastal structures.

The horizontal and vertical components of water particle velocity (u and w , respectively) can be determined from the velocity potential where

$$u = \frac{\pi H}{T} \left[\frac{\cosh k(d+z)}{\sinh kd} \right] \cos(kx - \sigma t) \quad (8)$$

$$w = \frac{\pi H}{T} \left[\frac{\sinh k(d+z)}{\sinh kd} \right] \sin(kx - \sigma t) \quad (9)$$

In deep water the orbits are circular throughout the water column but decrease in diameter with increasing distance below the water surface, to approximately die at a distance sufficiently far.

Pressure field is

$$p = -\rho g z + \frac{\rho g H}{2} \left[\frac{\cosh k(d+z)}{\cosh kd} \right] \cos(kx - \sigma t) \quad (10)$$

The kinetic energy and potential energy for a unit width of wave crest and for one wave length are

$$E_k = E_p = \frac{\rho g H^2 L}{16} \quad (11)$$

Energy in a wave per unit crest width E is

$$E = E_k + E_p = \frac{\rho g H^2 L}{8} \quad (12)$$

Wave Power, P , the wave energy per unit time transmitted in the direction of wave propagation is

$$P = \frac{E}{2T} \left(1 + \frac{2Kd}{\sinh 2kd} \right) \quad (13)$$

We have designed a prototype which has made some assumptions. Mainly it is concluded that the device is designed for a significant wave height that occurs most often in the place where you want to install.

The characteristics of the trochoidal wave near to Cartagena area (Node WANA2074090, see [Fig. 3]) are shown in Table 1. The formulations described above were used for analysis which input values of measured buoy [5], as the period (T_p), the height of significant wave (H_s) and anchoring depth. Velocity potential, speed of particle and pressure field are presented in [Fig. 6], [Fig. 7] and [Fig. 8] respectively.

Table 1. Trochoidal wave characteristics near to Cartagena

Trochoid Gravity Wave Calculation:		
Inputs:		
Period	T=	5 s
Wave Length:	Lo=	39.03274979 m
Wave Height:	Hw=	1.000 m
Sea Level:	z0=	0 m
Acceleration of Gravity:	g=	9.81 m/s ²
Water Depth:	d=	67 m
Density sea	ρ =	1025 Kg/m ³
Calculations:		
Steepness:	H/L=	0.02562
Max Steepness:	(H/L)max=	0.31831
Circular Wave Number:	k=	0.16097 rad/m
Amplitude:	A=	0.500 m
	k*A=	0.080
Phase Speed:	cw=	7.81 m/s
Frequency	σ =	1.257 rad/s
Pressure	p=	10055.25 Pa
Potential Energy	Ep=	24530.25 Julios
Kinetic Energy	E _k =	24530.25 Julios
Energy	E=	49060.50717 Julios
	n	1.000000018
Power	P=	7808.222371 Watts

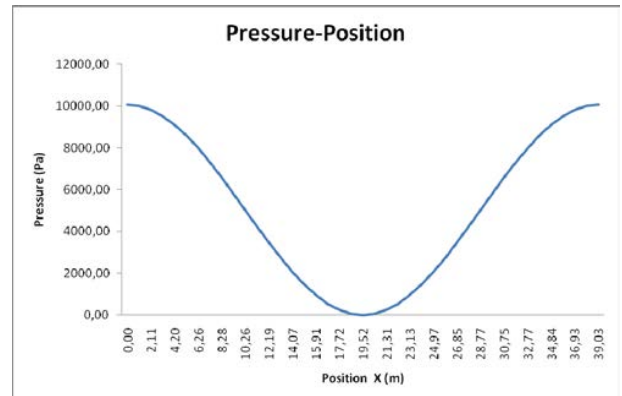

Fig.8. Pressure Field in function of the position of wave length. Eq. 10

IV. PROTOTYPE DEVELOPMENT

The design of the first prototype was made from reusable materials not therefore need not be non-functional as it produces a maximum of 5 volts (see [Figure 13]).

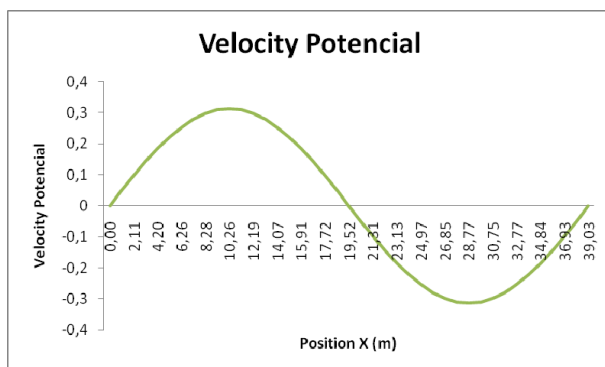

Fig.6. Velocity Potential. Eq. 5

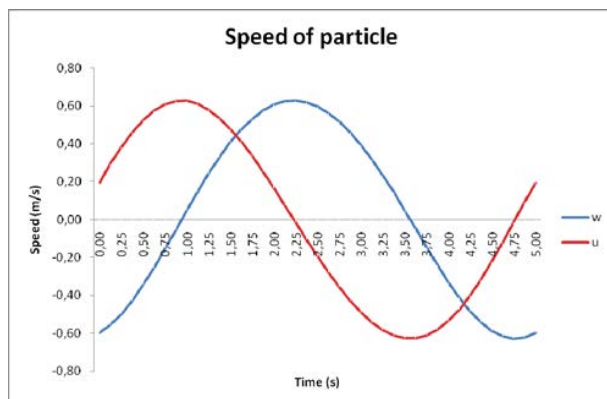

Fig.7. The horizontal and vertical components of water particle velocity (u and w). Eq. 8 and 9



Fig.13. Design of prototype

The project is currently in the phase of improving the design of the absorber and an experimental prototype. Manufacturing the prototype has been able to make the following conclusions (see Table 2) about our Point Absorber.

Table 2. Representation of the advantages and disadvantages

Point Absorber	Advantage	Problem
Operating status	Pendulum operation for small wave heights. Simple and robust mechanism. Low number of moving parts as the buoy's motion directly drives a crank mechanism, which in turn drives a rotary generator.	Mechanical stress especially in stormy conditions.
Mooring	Anchored to a fixed structure resistant to bad condition. Use the same structure for installing additional devices.	To install a support structure, it increases costs.
Power Generation	Electrical power can be generated using a standard rotary generator reducing development cost.	Mechanical losses added by crank mechanism. Efficiency reduced due to the change in inertia of the rotating generator.
Manufacturing	Simple Mechanical parts to machine. Rotary generators are in general less expensive than linear generators.	Large Mechanical parts adding weight. Specialist bearings to reduce mechanical losses.
Maintenance		The crank mechanism requires lubrication and polish, adding to the maintenance costs. Corrosion problems.

V. CONCLUSIONS

In this paper we have designed and developed a continuous production energy machine from trochoidal waves. The study of waves is focused in the geographic area of Cartagena, in particular, at Node WANA2074090, near the beach Gorguel, to produce electricity at a fish farm and a core of houses without access to the electricity grid. The device is designed for a significant wave height that occurs most often in the place of interest. A competitive advantage with the current arrangements is a low price, because it uses a simple, sturdy rotary generating mechanism. This work is focused on the development of wave energy mechanisms with low environmental impact.

VI. ACKNOWLEDGMENTS

The authors gratefully acknowledge the financial support from ETSINO, UPCT and the Organizing Committee of the MARTECH Workshop 2015.

VII. REFERENCES

- [1] OEPM. Oficial Española de Patentes y Marcas. Boletines OEPM / Energía marinas / Primer trimestre 2015. http://www.oepm.es/export/sites/oepm/comun/documentos_relacionados/Boletines/energias_marinas/2015_1_Trimestre_Energias_Marinas.pdf
- [2] M. Lafoz, M. Blanco, P. Moreno –Torres, G. Navarro, C. Vázquez y L. García – Tabarés. *Development of a project for direct conversion of wave energy into electricity*. Ingeniería Civil. 2014;176: 5-12.
- [3] OES. Ocean Energy Systems. Informe anual 2014. <http://report2014.ocean-energy-systems.org/country-reports/spain/research-and-development/>
- [4] Sorensen, R.M (2006). *Basic Coastal Engineering*. Chapter 2: *Two-Dimensional Wave Equations and Wave Characteristics*. Springer US. Online ISBN: 978-0-387-23333-8.
- [5] Puertos del Estado. Government of Spain. <http://www.puertos.es/eses/oceanografia/Paginas/portus.aspx>
- [6] Colli, V.D. , Cancelliere, P., Marignetti, F., Di Stefano, R., Scarano, M. (2006) "A Tubular-Generator Drive For Wave Energy Conversion"

Industrial Electronics, IEEE Transactions on, June 2006. Vol 53 (4), pages. 1152-1159.

[7] J. Falnes, *Ocean Wave Energy and Oscillating Systems: Linear Interaction Including Wave-Energy Extraction*, 1st ed. Cambridge, U.K.: Cambridge Univ. Press, 2002.