

# Concept Vessel: Green Desalination Barge

Tudela-Meroño, Dionisio; Gilabert, Javier; López-Palancar, Luis; López-Maestre, Tomás; León-Albert, Gerardo.

(Department of Chemical & Environmental Engineering, Universidad Politécnica de Cartagena, Spain)

**Abstract** - Water is essential to all known life forms; this covers 3/4 (71%) of the surface of the Earth. 97 percent of that water is salty water, which is found primarily in the oceans and seas; only 3 per cent of its volume is freshwater. Of the latter, only a 1 per cent is in liquid state. The remaining 2% is in solid state in layers, fields and ice shelves or sea-ice at high latitudes. Outside the polar areas, freshwater is found mainly in wetlands and underground aquifers, still often hard to reach.

Water needs for human consumption have increased drastically. That is why in some communities where the shortage of rainfall, extremely poor areas, natural disasters, or other many phenomena can cause the lack of freshwater for consumption. Different technologies to alleviate this lack have been generated. In the absence of water affecting many coastal countries this project try to give a new solution to the lack by designing a seawater desalination barge fueled with clean energy based on Fuel Cells.

**Keywords** - Barge, Fuel Cell, Desalination, Renewable energy.

## I. INTRODUCTION

Here we present a project of the first desalination barge with Fuel Cell (FC) worldwide. The design is based on previous Research and Development projects on Fuel Cells and desalination that took place in 2009 at the Polytechnic University of Cartagena, arising a patent [1]. Several companies such as Hidrotec® and Fuel Cell Energy Solutions GmbH, have been substantial part of the developed project. This modular barge has been design to fulfill the need of freshwater during droughts, even in stationary plants.

### A. Objectives

This project begins with the definition of the need that is intended to cover. As already specified in the preceding paragraph, either, by natural disasters, drought, etc., there is a lack of important drinking water in many parts of our society. The prototype project of this desalination barge aims to not only cater to those regions of water, but in addition to redoing it through the use of clean energy development such as Fuel Cells.

Maintaining environmental sustainability is a continuous goal to every human being. Fuel Cells are one of these technologies based on the chemical transformation of hydrogen and therefore, it can be considered as a fully sustainable process.

### B. Requirements

Desalination barge with electrical energy supplied by FC, propelled by electric azimuth thrusters. Notable features / project requirements are:

- Forms of the barge mathematically developable
- Autonomy for 60 days at sea
- Modularity of the project
- Wide range of operation
- Ability to behave as stationary plant
- Ergonomic design
- Vessel classified by DNV-GL [2]
- Strict compliance with SOLAS [3] and MARPOL [4]
- Electric propulsion (diesel-electric in case of emergency)
- Desalination capacity of 160 m<sup>3</sup>h
- 360 m<sup>3</sup> methanol tanks
- 2 x 300 kW diesel Gensets
- 80 m<sup>3</sup> diesel tanks
- Launch of collecting pipe Lars
- Superstructure with habitability for crew
- Duplication of control panels
- Valves and remote control of main equipment
- Bridge 360° view
- Dynamic Positioning.

## II. PROPOSAL OF SOLUTION

A desalination barge with power supply by «Fuel cell» has been designed after the analysis and following the project requirements. The main features of the barge are:

- Length 50 m
- Beam 9.2 m
- Hull depth: 5 m
- Estimated draft: 3 m
- Estimated displacement: 800 tm
- Block coefficient: 0.67
- Height of superstructure on deck 6 m
- Height of antenna and stick of signals on superstructure 4m.

Figure 1 shows the general arrangements on the barge

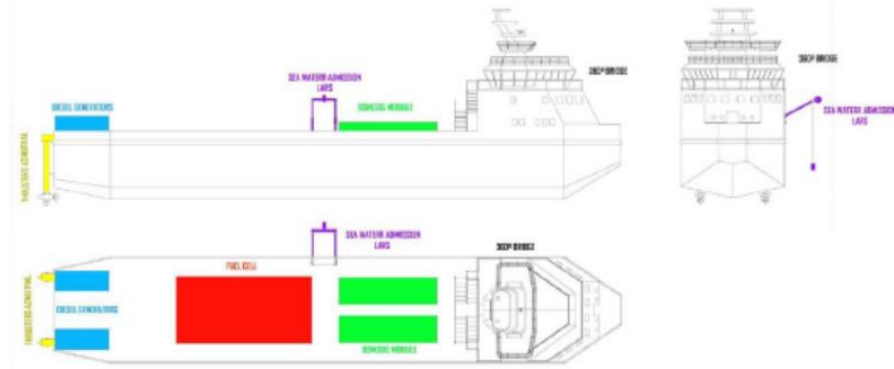

“Fig.1. General Arrangement”

### III. APPLIED TECHNOLOGY

The barge will be built in «mild steel», typical material for the construction of ships and which has excellent characteristics for the marine environment. The base structure will be composed of longitudinal girders in order to perform the bending moments along the length of the ship, bearing the cross side stiffeners to the first. The girders and the stiffeners will be properly distanced alike. The span between the structural stiffeners shall be such that, large loads that will support cover load due to the weight of big installed equipment, will be supported by girders both longitudinal and transverse.

The scantling of the entire structure has been made according to regulations of the classification society «Det Norske Veritas», including aluminum superstructure, which include its construction material will be at first base, which may be composite, according to specification of the ship-owner.

The space reserved for the Fuel Cell will have both bow and stern of the same, watertight bulkheads forming a compartment watertight, which in case of emergency, isolate the equipment. For this purpose, all spaces not assisted working under the cover of bad weather as a local, due to duplication of control panels in bridge and controlled remote valve control are designed.

### IV. MODULARITY

The barge will be divided into 5 blocks:

#### A. Central body

It will house the FC and the desalination equipment, as well as the main water and fuel tanks. It is designed to be able to work independently from the rest of the blocks, so it can serve as stationary station, according to needs and requirements of the customer. Furthermore, it must accommodate all pumps, piping, valves, and auxiliary pipes, etc.

#### B. Stern Body

It will house the propulsion and Gensets of 300 kW each one. This space will serve as a propulsion system and steering of the barge. A non-structural diesel fuel tank will be placed under the deck to supply fuel to the gensets on the weather deck.

#### C. Bow Body

Bow body only have functions for behavior in the sea, anchoring and mooring. The freeboard will fulfill the DNV regulations.

#### D. Keel

The keel compartment will improve the stability and behavior at sea. It may contain desalinated water if necessary. It has a triangular shape to facilitate the construction at the shipyard.

#### E. Superstructure

It will house the habitation (for eight crew members), kitchen, laundry, workshop, storeroom and, on the top, the bridge with duplication of the equipment's control. The position of chief pilot will be one of the most important areas because it has all the control data of the boat: Gensets, Fuel Cell, desalination plants, tanks, systems of electronic security as the system against fire, lights, control panel of bilge and transfer pumps, rudder angle, electronic, air conditioning, etc...Also available day and night camera to see work over deck, alarm with red light and buzzer approved, responding to the criterion of failsafe operation. Available Chart-room table, Hi-Fi and CD player with respective speakers, will have sliding side windows of tempered with automatic cleaning system and antiglare filter.

Figure 2 shows a 3D scheme of the superstructure.

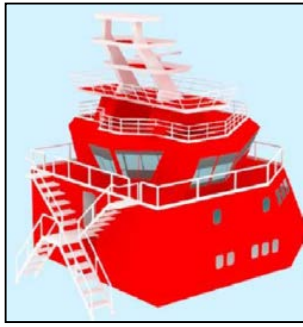

“Fig.2. 3D picture to the superstructure”

## V. DOUBLE APPLICATION

However, exist a second reason for choosing this building block system. As we discussed previously, this desalination barge project allows to use the central module as an independent unit, where there are the main equipment for proper operation. So, inside this block, are installed all feeding and transfer pumps, as well as the supply of salt water, brine and water desalinated. In this way, the barge can works on the high seas, and its central module, will be works as an autonomous and independent unit. For example, this module can works onboard a single-hull tanker (in N units of this type) or maybe in stationary applications.

## VI. SYSTEMS

### A. Main system of energy (Fuel Cell)

Fuel Cell supplied by «Fuel Cell Energy Solutions GmbH» is an enclosure equipment with the all necessary equipment for the proper and secure operation.

Installation on board the barge implies the need of a suitable structural reinforcement and a bedplate with resilient mounts. The different support systems for the Fuel Cell have been described in their corresponding sections. For unattended spaces, the duplicity of Fuel Cell control panels are projected on the bridge.

### B. Secondary system of energy generation (Gen)

Formed by two generators diesel 300 kW 50 Hz, with MTU diesel engines, air-cooled, mounted on a bedplate, with sound enclosure. The generators incorporate starting batteries and daily use fuel tank.

For direct current consumers are planned a AC line available after the general panel of a DC power transformer, including a set of batteries in parallel with charger and power of 4000 W enough to maintain the condition of the vessel .

### C. Propulsion and Maneuver system

The system will be mainly composed by two electrically powered azimuth thrusters, each one with 100 kW output, providing a top speed limited to 4 knots according to the Classification Society requirements.

A dynamic positioning (DP-1) GPS system will maintain the boat on a fixed point for the extraction of the water. The barge will correcting its location and course according to the technical specifications of the project, which must be requested by the owner, within, the logical limits of use of the system. The suitable position of the vessel in high sea working in DP will always be aft predominantly from the force of the wind and current, thereby saving energy using this method is approximately 15%, due mainly to hydrodynamic support provided by Stern block. Figure 3 shows a scheme of the DP propellers.

The maneuvering of vessel will consist electrically by the vector sum of the water jet that azimuth thrusters emit.

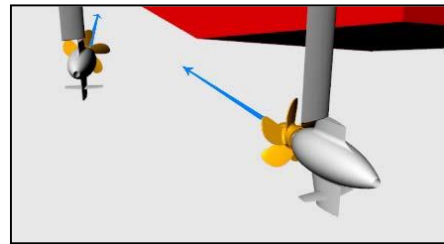

“Fig.3. Dynamic positioning system”

### D. Fire Protection system

This project includes preventive and fire detection on board, as indicated in chapter II-2 of SOLAS, including acoustic and visual alarms on the bridge. In addition the system is constituted with three principal means of extinction in a possible case of emergency by ignition, described below:

- ✓ Portable firefighting composed of fire extinguishers type 2, distributed by the superstructure of the ship.
- ✓ Locals below the weather deck, will be provided with a system of detection and automatic response by sprinklers. The system will be full pipe preloaded with freshwater, and will works with seawater. On board will be one or more fire pumps, and one of them (the non-emergency) could be used by other systems such as the bilge.
- ✓ The Fuel Cell chamber will be equipped with a system of flood by inert gas (N<sub>2</sub>) with activation by alarm in the Cell, with visual and acoustic indicators, and a watertight seal in the local, with delay for evacuation of the crew inside.

### E. Methanol system

The ship contains four structural tanks to store methanol and one service tank, with a total capacity of 360 m<sup>3</sup>, enough for 60 days operation.

All these tanks have a system of detection of gases with overpressure valves, grounded to avoid static electricity, and a system of inert atmosphere and sockets filled with tubes that will come to the bottom of the tanks.

All lines of methanol will be double-walled (inert atmosphere by N<sub>2</sub> to 2 bar), with grounding, nitrogen in the

wrapped pressure gauges, vapors of methanol, connected to a system of control and alarm, and methanol leakage sensors-detectors. Such pipes shall be painted with a different color and labels of that through them circulates methanol, indicating also the direction of the flow.

REMARK: It is important to note that the applicable shipping and storage of methanol recommends but does not impose to install tanks of double wrapped, making it clear that this recommendation will be mandatory in the not-too-distant future [5]. Since this barge is a demonstrator, he has been chosen to simplify the system, placing on board simple structural tanks with redundancy of prevention and action of fire and casualty. To avoid any kind of incident, all methanol tanks will be filled with an atmosphere of nitrogen to inert the atmosphere inside of them

#### F. Nitrogen System and Methanol Monitoring

This system is a preventive and safety system, and as already described in the fire protection system, is an effective equipment for transportation, storage and work with methanol on board the barge demonstrator. It is mainly composed by pressurized nitrogen racks of bottles (2 racks of 12 bottles to 150 bars) arranged on the open deck, always protected from splashing water and sea spray. The system will equipped with motorized valves and pressure reducing valves, they will give service to the system of blanketing of tanks, double wrapped pipes and pumps that work with methanol. The entire system, as in the case of methanol system, will have ground in its entirety.

On the other hand, the monitoring system gives the user the general vision of the system state (total pressures, partial pressures, leakage indicators and other alarms) in order to minimize any risk on board. As with other systems, it may act on the valves remotely operated through the motorization of the same.

#### G. Desalination system

Desalination modules, as well as sand filters are supplied by "HIDROTEC Water Treatment, S.L.". This system has been designed for easy maintenance, and each module could be disembark if necessary (Fig. 4). Similarly the maintenance are planned accordingly with stays in port for the supply of fuel and food, and change/rest of the crew.

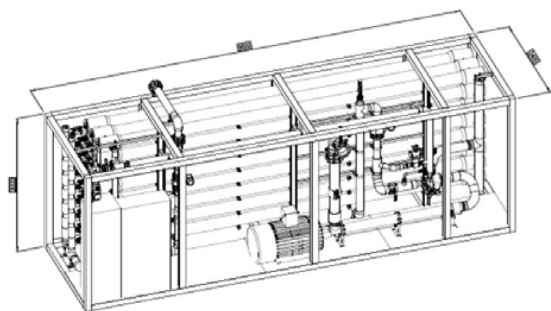

“Fig.4. Reverse Osmosis module”

## VII. PROJECT MANUAL

This project has been conceived as a demonstrator of a modular desalination barge with power generation through fuel cell. This section will inform the necessary connotations for the proper use of the design.

Day 3 the barge sail to the sea propelled with its two azimuth thrusters with the cruising speed set by the societies of classification of 4 knots. It will be lead to a particular point previously fixed for the extraction of water which will depend on both the situation and the morphology of the coast.

Once at the point of extraction the dynamic positioning will be activated, heading predominantly between tide and wind or composition of both, with the propellers to windward, in order to minimize the fuel consumption.

Water extraction will take place through the launch of a hose by a launching gantry (in later LARS). Plumb or solid weight (Clump Weight) powered through a Power Pack to power the hydraulic system of the LARS.

While the barge has a storage tank under the double hull, this has been designed to transfer the desalinated water to a tanker shuttle (shuttle ship) or a non-propelled barge carried to the point using tugboats.

Where it is susceptible to contamination of the water desalinated by seawater will require that the available big hoses in its final end will be provided of a electric conductivity sensor. This situation will be favorable when the demonstrator is operating near the coast and funneling water directly to tanks ashore through branches of flexible hoses. To minimize the possibility of desalinated water to be contaminated by seawater, whenever feasible, the hoses will go on surface. For obvious reasons, here the use of demonstrator as a stationary plant, has not been considered.

## VIII. CONCLUSIONS

Our demonstrator has been designed to deliver desalinated seawater when needed at a lower cost than the conventional wisdom desalination plants procedures. Its environmentally friendly energy technology and efficiency make it one of as a solutions to deliver drinking water either in catastrophes or to coastal population without access to drinkable water.

## REFERENCIAS

- [1] López Maestre, T., Gilabert Cervera, J., León Albert, G. y López Palancar, L. 2011. Plataforma flotante autopropulsada de desalación, potabilización, almacenamiento y distribución de agua de mar. Patent number ES 2 338 205 B1
- [2] DNV- GL Parts 1-6. 2015 revisions.
- [3] SOLAS 1975 and 1988. 2012 revisions.
- [4] MARPOL Annex I-V. 1973/1978.
- [5] Methanol safe handling manual- Methanol Institute.