

THE EFFECT OF HYSTERESIS ON THE FLUXGATE SENSOR BEHAVIOR

A. Lopes Ribeiro¹, O. Postolache²

Instituto de Telecomunicações^{1,2}, Instituto Superior Técnico¹
Av. Rovisco Pais 1, 1049-001 Lisboa, Portugal, e-mail: arturlr@ist.utl.pt

Abstract - This paper describes the principle of operation of the fluxgate sensors. The effect of the magnetic hysteresis was specially taken into account. It was found that the hysteresis does not distort the linear characteristic of these devices.

I. INTRODUCTION

Different methods and techniques have been used for the measurement of magnetic fields. They are based on different phenomena, such as induction, Hall effect, magneto-resistance, magneto-optic effects or super-conducting quantum effect.

In this paper our aim is to describe the fluxgate technique [1,2] and to investigate the influence of the ferromagnetic hysteresis on the device behavior.

The fluxgate technology, to measure weak magnetic fields, was used in large scale during the Second World War for the detection of submarines. Due to the good sensitivity of these magnetometers, they were largely utilized in geophysics to measure the earth's magnetic field, because they were accurate enough to sense small fluctuations, being capable of measuring the perturbations derived from the presence of large amounts of underground materials such as oil or other minerals of economic value [3]. This method is useful for the measurement of fields with intensities below 1 mT with resolutions in the range 0.1-10 nT.

The fabrication of integrated devices [4] including very small ferromagnetic cores, using materials with high permeability, low coercive force, low magnetostriction and a wide range of possible frequency operation was the technological ground for the construction of new devices. Nowadays, fluxgate magnetometers are used in different fields, being of special mention their utilization aboard spacecrafts to monitor the outer earth magnetic shield or in more remote zones of the solar system [5], in electronic compasses, and to replace SQUIDS in biomedical applications [6].

II. OPERATION PRINCIPLE

Different designs of fluxgate devices can be found in the specialized literature. Our setup uses the configuration represented in Fig.1, whose behavior is easy to understand. Two equal ferromagnetic longitudinal cores of permalloy form this structure. Each core has one winding with N_1 coils. A second winding with N_2 coils embraces the two cores. A sine wave alternate excitation current i_{ex} , of frequency f_0 and rms-value I_{ef} , is injected in the lower windings with opposite magnetization effect. An external dc magnetic field H_0 affects equally the two cores. The magnetizing effect of the field H_0 acts differently in the two cores.

In the case of a non-vanishing field H_0 , a voltage u_0 will be detected, which contains even harmonics of the excitation frequency f_0 .

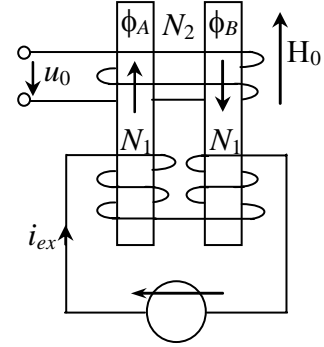

Fig.1. Fluxgate configuration used to measure an external dc-field.

III. THIRD ORDER POLYNOMIAL MAGNETIC CHARACTERISTIC

To show this effect let us assume that a polynomial expansion represents well the ferromagnetic characteristic of each core. Thus, the flux ϕ is written in terms of the odd powers of the total equivalent magnetizing current $i_s = N_1 i_{ex} \pm L_0 H_0$, the '+' signal being taken on the left core and the '-' signal on the right core. The L_0 parameter translates the field H_0 in terms of an equivalent current.

$$\phi = A_1 i_s - A_3 i_s^3 \quad (1)$$

The output voltage u_0 will be given by (2).

$$u_0 = N_2 \frac{d}{dt} (\phi_A - \phi_B) = 12 N_2 A_3 N_1^2 I_{ef}^2 L_0 H_0 \omega_0 \sin(2\omega_0 t) \quad (2)$$

This output voltage is, in this case, purely sinusoidal of frequency $2f_0$, because the assumed magnetic characteristic was truncated to the third power of the magneto-motive force. It is also important to note that u_0 presents an amplitude proportional to the dc-field H_0 , indicating that this method can be used to measure this current. If more odd powers of the magneto-motive force were present in the magnetic characteristic the output voltage would include more even harmonics of the excitation current.

In Fig.2 we show the time evolution of the magnetic fluxes ϕ_A and ϕ_B , and their difference $\phi_A - \phi_B$. The dc component is naturally eliminated in u_0 , remaining the second harmonic.

The polynomial characteristic in (1) includes the nonlinear effect due to magnetic saturation. However, the effect of the magnetic hysteresis must be taken into account, because those materials always present some degree of hysteresis.

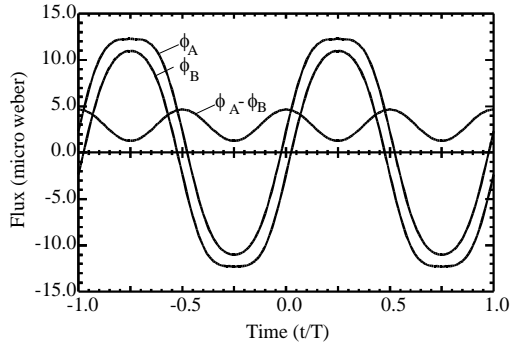

Fig.2. Time evolution of the fluxes and of their difference.

IV. THE EFFECT OF THE MAGNETIC HYSTERESIS

The magnetic characteristic represented in Fig. 3 was chosen, being assumed that the excitation field is always strong enough to drive the material into the saturation, in order to guarantee that the maximum hysteresis cycle is always described.

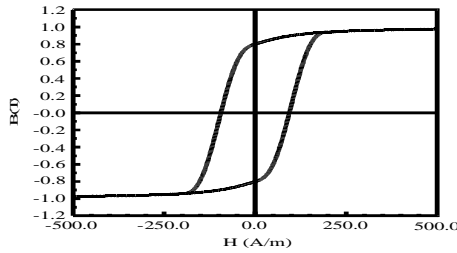

Fig.3. Hysteretic magnetic characteristic.

The configuration described in Fig.1 was also used in this case, and the resulting fluxes are shown in Fig.4. The output fluxes and the voltage u_0 are quite different from the previous example.

The observation of the output signal spectrum shows that all the even harmonics of the excitation current are now present. However this fact is not due to the hysteretic character of the core material, but only to the non-linearity, as was proved by using different magnetic characteristics, with different coercive fields. Even in the case of zero coercive field, a large number of even harmonics were always present. However, the presence of hysteresis increases the weight of the harmonics of higher order. The next step was to investigate the linearity of the fluxgate when the new hysteretic characteristic was considered.

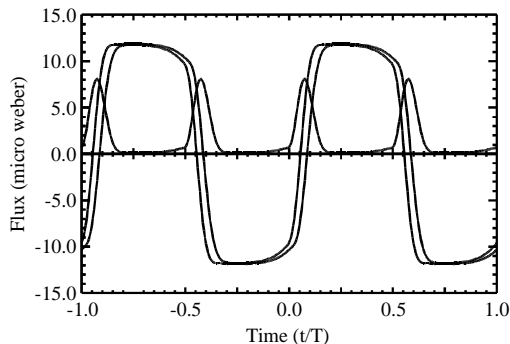

Fig.4. Time evolution of the fluxes and of their difference with magnetic hysteresis.

V. OUTPUT LINEARITY RESULTS

In the simple example when a third order polynomial magnetic characteristic was considered it was shown that the output voltage amplitude was proportional to the dc-field H_0 . It was necessary to investigate the linearity of the fluxgate when a much more general characteristic was considered. Therefore, the magnetic hysteric cycle was taken into account and the magnetic fluxes ϕ_A and ϕ_B , and their difference was determined. The output voltage waveform was determined by numerical differentiation and a discrete Fourier transform was used to investigate the relation between the second harmonic in u_0 and the intensity of H_0 .

It was verified that this relation is very close to linearity. Our next step was to investigate the possible linearity between the other harmonics present in u_0 and H_0 . It was verified that for the other harmonics the linearity was not so perfect, but was still very close. We then represented the root mean square value and the peak value of the output voltage and a close linearity was also verified.

In Fig.5 we represent these last results graphically. The sequence of curves, from bottom to top, represents the second harmonic, the fourth harmonic, the root mean square value and the peak value.

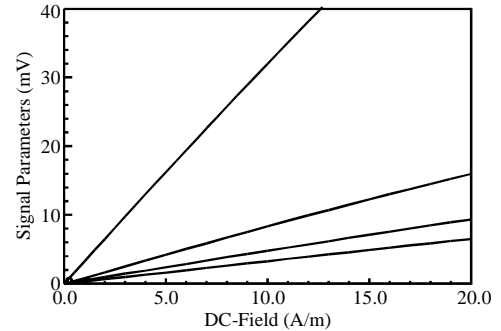

Fig.5. Output waveform parameters versus dc-field in the ferromagnetic cores.

REFERENCES

- [1] D. I. Gordon, R. E. Brown, "Recent Advances in Fluxgate Magnetometry", *IEEE Trans. on Magn.*, vol. 8, N.1, pp. 76-82, 1972.
- [2] F. Primdahl, "The Fluxgate Mechanism, Part I: The Gating Curves of Parallel and Orthogonal Fluxgates", *IEEE Trans. on Magn.*, vol. 6, N.2, pp. 376-383, 1970.
- [3] J. S. Hwang, H. S. Park, "Electronic Compass Using Two-axis Micro Fluxgate Sensing Element", *12th Int. Conf. on Solid State Sensors, Actuators and Microsystems*, Boston, vol. 2, pp. 1618-1621, 2003.
- [4] H. Joisten, B. Guilhamat et al, "Integrated Solutions to Decrease Micro-Fluxgate Sensors Noise", *IEEE Trans. on Magn.*, vol. 40, N.4, pp. 2649-2651, 2004.
- [5] A. Balogh, "The Ulysses Magnetometer", *IEE Colloquium on Satellite Instrumentation*, pp. 2/1-2/3, 1988.
- [6] A. Platil et al, "P1-35: Fluxgate can Replace SQUID for Lung Diagnostics", *Proceedings of IEEE Sensors 2002*, vol. 1, pp. 321-324, 2002.